

## ST-01 SPEED GATE

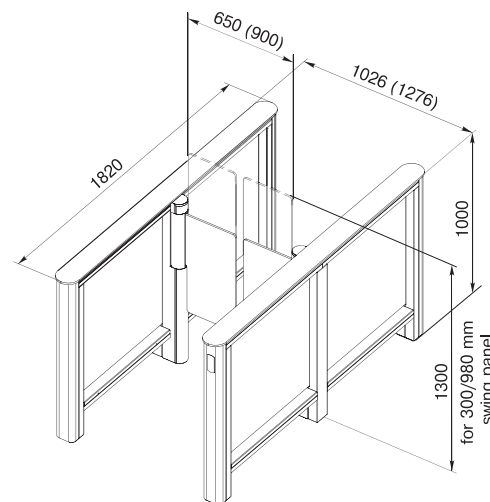

Three sizes of swing panels  
 300x600 mm  
 300x980 mm  
 430x600 mm

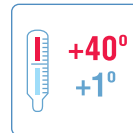

### Application

The ST-01 speed gate with swing panels is designed in a modern and elegant style and provides an ideal contactless solution for access control at sites with high aesthetic and comfort requirements. The ST-01 is perfectly suitable for a wide range of indoor applications and can be installed in offices, banks, administrative buildings, exhibition and business centres.

The ST-01 speed gate is available with three different sizes of swing panels. The system of infrared sensors ensures the security of passage at high throughput.

In emergency situations after receiving a signal from an ACS or an emergency button the swing panels are opened in a predetermined direction, in case of a power loss the swing panels are unlocked.

### Delivery set

- two gate posts with built-in electronics
- two swing panels
- remote control panel

### Design

The ST-01 is equipped with two LED directional indicators on the front panels and the LED indication of the current mode (open/closed) on the top cover.

The gate housing has specially designed places for concealed mounting of proximity card readers (produced by PERCo or other manufactures).

### Materials and Finishes

Gate posts – stainless steel

Filler panel (for gate posts) – 8 mm tempered glass

Top covers – 10 mm tempered glass

Swing panels – 10 mm tempered glass